

M P AGRO

THE M.P. STATE AGRO INDUSTRIES DEVELOPMENT CORPORATION LIMITED
PANCHANAN, 3rd FLOOR, MALVIYA NAGAR, BHOPAL
PHONE - 0755-2551652, 2551756, 2761392 FAX 0755-2557305,
EMAIL: mpagrohobpl@gmail.com WEBSITE: www.mpagro.org

RCO DOCUMENT

FOR SUPPLY OF
PRECAST CONCRETE
REINFORCED BENCH
FOR THE YEAR 2021-22

DUE ON 23.07.2021

RCO DOCUMENT FEES

Rs. 4000 + 720 (18%GST) = 4720

(Four Thousand Seven Hundred Twenty Only) Shall be paid.



**THE MADHYA PRADESH STATE AGRO INDUSTRIES DEVELOPMENT
CORPORATION LIMITED**

"PANCHANAN" 3rd FLOOR, MALVIYA NAGAR, BHOPAL

Phone (0755) - 2551652, 2551756, 2551807, Fax: 0755-2557305

LIST OF ANNEXURE OF RATE CONTRACT BID DOCUMENT

SN	PARTICULER	ANNEXURE	PAGES NO
1	RCO NOTICE	I	03
2	DISCLAIMER & ABBREVIATIONS, DEFINITIONS AND INTERPRETATION	II	04 to 06
3	TITLE, TIME SCHEDULE, RCO FEE & EMD	III	07
4	ELIGIBILITY OF BIDDER & DETAILS OF ITEM	IV	08
5	MANDATORY DOCUMENTS TO BE SUBMITTED IN HARD COPIES	V	09
6	APPLICATION FORM	VI	10
7	CONDITIONS OF RATE CONTRACT	VII	11 to 22
8	LETTER OF UNDERTAKING AND DECLARATION	VIII	23
9	FINANCIAL BID FORMAT	IX	24
10	DECLARATION OF BLACKLISTING	X	25
11	DRAFT AGREEMENT	XI	26 to 27
12	TECHNICAL SPECIFICATION OF ITEM		28 to 31
		Total No of Pages -	31

ANNEXURE - I



THE MADHYA PRADESH STATE AGRO INDUSTRIES DEVELOPMENT CORPORATION LIMITED

"PANCHANAN" 3rd FLOOR, MALAVIYA NAGAR, BHOPAL
Phone (0755)- 2551652, 2551756, 2761392, Fax: 0755-2557305

HO : MKTG/PACK HOUSE/2021/

Dated: 01.07.2021

E - RCO NOTICE

Online RCO are invited for supply of PRECAST CONCRETE REINFORCED BENCH FOR THE YEAR 2021-22.

Manufacturer of these items may participate in the RCO on the basis of Eligibility Criteria mentioned in the documents.

RCO documents can be purchased by paying RCO fee Rs. 4000 + 720 (18% GST) = 4720 (Four Thousand Seven Hundred Twenty Only) each online up to following date :-

S.N.	Name of Item	Last Date to Submit	EMD
01.	FOR SUPPLY OF PRECAST CONCRETE REINFORCED BENCH	23.07.2021	1,00,000/-

The detailed RCOs and other information can be seen at Corporation's website www.mpagro.org and www.mptender.gov.in. Amendments, if any, will be published only on above websites. No further notification will be made in the newspapers.

DY. GENERAL MANAGER (MKTG)



THE MADHYA PRADESH STATE AGRO INDUSTRIES DEVELOPMENT CORPORATION LIMITED

"PANCHANAN" 3rd FLOOR, MALAVIYA NAGAR, BHOPAL
Phone (0755)- 2551652, 2551756, 2761392, Fax: 0755-2557305

DISCLAIMER & ABBREVIATIONS, DEFINITIONS AND INTERPRETATION

A. DISCLAIMER:

1. The information contained in this RCO Document has been prepared solely for the purpose of providing information to the interested parties, and is not in any way binding on MP AGRO.
2. By accessing this RCO Document, Prospective Bidder agrees that MP AGRO will not be liable for any direct or indirect loss arising from the use of the information and the material contained in this RCO Document.
3. Prospective Bidder's access to it does not imply a license to reproduce and / or distribute information contained therein and Bidder not allowed to any such act without the prior approval of MP AGRO.
4. In case any Prospective Bidder finds any discrepancy or omission in the any part of the RCO Document/or he has any doubt to their meaning, he should notify the MP AGRO minimum 10 days prior to RCO closing date. MP AGRO may clarify and send instruction to all bidders for correction through portal / Website, if necessary. It however, does not entitle the bidder to seek any extension of RCO closing date.
5. It shall be understood that every endeavor has been made to avoid any error which can materially affect the basis of the RCO and All bidder shall take upon himself and provide for the risk of any error which may subsequently be discovered and shall make no subsequent claim on account thereof.
6. The submission of the RCO will be deemed to imply that the Bidder fully understands the scope of work involved and has read and understood all conditions of the RCO document and his liabilities and responsibilities in respect of the RCO.
7. Information received against any discrepancy (up to due date and time as mentioned above) will be examined and, if any, amendments required same will be uploaded on portal as Corrigendum with RCO document. If no amendments are required the Bidder will have no right to raise objection.
8. The Corporation reserves the right to reject any or all of the RCO document submitted in response to this RCO at any stage without assigning any reasons whatsoever.
9. The Corporation reserves the right to change any or all of the provisions of this RCO. Such changes would be intimated to prospective bidders through portal.

B. ABBREVIATIONS, DEFINITIONS AND INTERPRETATION

01. The Corporation/MP AGRO means M.P. State Agro Industries Development Corporation Ltd.
02. Beneficiary/Consignee means The person/department who wish to purchase the items through this Corporation.
03. Application forms/the document means Application forms and all other relevant annexures/documents
04. Applicant/Bidder means The Manufacturer eligible participants who submits RCO for supply and installation of Items as per document.
05. EMD means Earnest Money Deposit
06. Managing Director means Managing Director of MP State Agro Industries Development Corporation Ltd Bhopal.
07. RCO means - Rate Contract Offer
08. DOH means - Director of Horticulture, Govt. of MP
09. "Contract" means and includes the invitation to RCO, instructions to Bidder, RCO, acceptance of RCO, Conditions to Contract, particulars and the other conditions specified in the acceptance of RCO and includes repeated orders which have been accepted or acted upon by the/ for the Supplier and a formal agreement, if executed;
10. The "Suppliers" means the person, firm or company with whom the order for the supply is placed and shall be deemed to include the suppliers' successors (approved by MP AGRO) representatives, heirs, executors and administrators, as the case may be, unless excluded by the terms of the contract;
11. "The Inspecting Agency" means the person specified in the contract for the purpose of inspection of materials or services under the contract and it is an Agency authorized by MP AGRO and/or Director of Horticulture/Director Agriculture/Director Agricultural Engg.
12. "The Purchaser" means the MP STATE AGRO INDUSTRIES DEVELOPMENT CORPORATION LIMITED, (MP AGRO).
13. "Materials" means the goods specified in the contract which the Supplier has agreed to supply under the contract;
14. "Test" means such test as is prescribed by the particulars or considered necessary by the MP AGRO/Director of Horticulture/ other govt. department to be performed or made by the inspecting agency acting under an order issued by MP AGRO/Director of Horticulture/other govt. department.
15. Terms and expression not herein defined shall have the meanings assigned to them in the Indian Sale of Goods Act, 1930 (as amended) or the General Clauses Act, 1897 (as amended), or the Indian Contract Act, 1872 (as amended),as the case may be.

16. Contract shall be governed by the Laws of India for time being in force.
17. Words importing the singular shall include the plural and vice versa, words importing any gender shall include all other genders, words importing persons shall include bodies corporate, unincorporated associations and partnerships and vice versa. References to whole shall include the part and vice versa.
18. The Courts of the place from where the acceptance of the RCO has been issued shall alone have jurisdiction to decide any dispute arising out of or in respect of the contract.
19. A person signing the RCO or any other document in respect of the Contract on behalf of the supplier without disclosing his authority to do so shall be deemed to warrant that he has authority to bind the Supplier. If it is discovered at any time that the person so signing has no authority to do so, MP AGRO may, without prejudice to any other right or remedy with MP AGRO, cancel the contract and make or authorize making of a purchase of the materials at the risk and cost of such person, and hold such person liable to MP AGRO for all costs and damages arising from the cancellation of the contract including any loss which MP AGRO may sustain on account of such purchase.
20. For all purposes of the contract, including arbitration there under, the address of the Supplier mentioned in the RCO shall be address to which all communications to the Supplier shall be sent, unless the Supplier has notified change by a separate letter containing no other communication and sent by registered post acknowledgment due to MP AGRO. The Supplier shall be solely responsible for the consequence of an omission to notify a change of address in the manner aforesaid.



THE MADHYA PRADESH STATE AGRO INDUSTRIES DEVELOPMENT CORPORATION LIMITED

"PANCHANAN" 3rd FLOOR, MALAVIYA NAGAR, BHOPAL
Phone (0755)- 2551652, 2551756, 2761392, Fax: 0755-2557305

TITLE, TIME SCHEDULE, RCO FEE & EMD

(A) TITLE:

PRECAST CONCRETE REINFORCED BENCH

(B) TIME SCHEDULE:

Stages of Bidding	Scheduled time	Scheduled Date
Purchase of RCO	upto 02.00 PM	23.07.2021
Last date of submission	upto 02.30 PM	23.07.2021
Opening of technical bid	upto 03.00 PM	26.07.2021 (Tentative)

Financial Bid of the successful bidders will be opened on the date decided by corporation which will be intimated to bidders & published on website in due course of time.

Each stage will take place on the date and time mentioned against them. However if the date and time is changed/ postponed information in this regard will be published on corporation website www.mpagro.org only.

(C) RCO FEE & EMD:

The RCO invited under e-RCO system and bidding process will have following steps:

RCO FEE	<i>Rs. 4000 + 720 (18%GST) = 4720 (Four Thousand Seven Hundred Twenty Only) Shall be paid online. (Non Refundable)</i>
EMD	<i>Rs 1,00,000/- (One Lakh Only) Shall be paid online.</i>
<u>NO EXEMPTATION IS APPLICABLE FOR RCO DOCUMENT FEE AND EMD</u>	

Note : If RCO is cancelled or RCO of any Bidder is rejected. EMD amount so deposited will be refunded online. No interest shall be paid on EMD amount.



THE MADHYA PRADESH STATE AGRO INDUSTRIES DEVELOPMENT CORPORATION LIMITED

"PANCHANAN" 3rd FLOOR, MALAVIYA NAGAR, BHOPAL
Phone (0755)- 2551652, 2551756, 2761392, Fax: 0755-2557305

ELIGIBILITY OF BIDDER & DETAILS OF IMPLEMENTS OFFERED

ELIGIBILITY :

- (i) Bidder should be original equipment manufacturer for the PRECAST CONCRETE REINFORCED BENCH - Bidder should submit document issued by Distt. Industries Center (DIC) showing name of equipment specifically as Other Manufacturing.
Dealers are not eligible to submit bid on behalf of manufacturer.
- (ii) Bidder will have to submit competency certificate issued by govt. industries department of feasibility report issued by competent agency (competent agencies are the institutions having authority to do so by quality council of India.
- (iii) Other necessary requirements for eligibility shall be as mentioned in Rate Contract BID document (RCO)

DETAILS OF ITEMS :

The Bidder may offer rates for the following Items :-

1. PRECAST CONCRETE REINFORCED BENCH WITH ARMREST WITH SEATING CAPACITY OF FOUR PERSONS.
2. PRECAST CONCRETE REINFORCED BENCH WITH ARMREST WITH SEATING CAPACITY OF THREE PERSONS.
3. PRECAST CONCRETE REINFORCED BENCH WITHOUT ARMREST WITH SEATING CAPACITY OF TWO PERSONS.

Minimum specification, Drawing Design & Sample Images of above items are given on page no. 28 to 34

**Dy. General Manager
{Marketing}**



THE MADHYA PRADESH STATE AGRO INDUSTRIES DEVELOPMENT CORPORATION LIMITED

"PANCHANAN" 3rd FLOOR, MALAVIYA NAGAR, BHOPAL
Phone (0755)- 2551652, 2551756, 2761392, Fax: 0755-2557305

MANDATORY DOCUMENTS TO BE UPLOADED & TO BE SUBMITTED IN HARD COPIES

(A) MENDATRY DOCUMENTS TO BE UPLOADED:

01. RCO documents duly signed on each page with office seal affixed.
(Page 1 to 34)
02. Copy of document issued by Distt. Industries Center (DIC) showing as manufacturer "Other Manufacturing" Head.
03. Test Report Issued by any NABL Accredited Laboratory for Back Rest Plank Part, Both RCC Legs Parts & Seating Plank Part. Lab Test should be conducted to assess Value of **Average Compressive Strength N/mm²** which should not be less than **30 N/mm²**
04. Application form duly filled as par **Annexure - VI**
05. Valid proof of authority to signing the document.
06. GST Registration certificate.
07. Affidavit from the Bidder that their firm has never ever been blacklisted by any Govt. organization, semi Govt. organization or any corporation till date. (on Bidder's Letter Head)
08. Competency certificate from Industries department or feasibility report from authorized agencies should be enclosed for each tendered item separately
09. Letter of Undertaking & Declaration **Annexure - VIII**
10. Financial Bid as per schedule **Annexure - IX**

(B) TO BE SUBMITTED IN HARD COPIES:

01. RCO documents duly signed on each page with office seal affixed.
(Page 1 to 34)
02. Copy of document issued by Distt. Industries Center (DIC) showing as manufacturer "Other Manufacturing" Head.
03. Test Report Issued by any NABL Accredited Laboratory for Back Rest Plank Part, Both RCC Legs Parts & Seating Plank Part. Lab Test should be conducted to assess Value of **Average Compressive Strength N/mm²** which should not be less than **30 N/mm²**
04. Application form duly filled as par **Annexure - VI**
05. Valid proof of authority to signing the document.
06. GST Registration certificate.
07. Affidavit from the Bidder that their firm has never ever been blacklisted by any Govt. organization, semi Govt. organization or any corporation till date. (on Bidder's Letter Head)
08. Competency certificate from Industries department or feasibility report from authorized agencies should be enclosed for each tendered item separately
09. Letter of Undertaking & Declaration **Annexure - VIII**

APPLICATION FORM

To

Managing Director
M P State agro Industries Development Corporation Ltd
3rd Floor, Panchanan Bhawan Malviya Nagar
Bhopal

Sub :- RCO for supply of PRECAST CONCRETE REINFORCED BENCH FOR THE YEAR 2021-22

Dear Sir,

Kindly accept our application for RCO Document for supply of PRECAST CONCRETE REINFORCED BENCH FOR THE YEAR 2021-22 in the state of Madhya Pradesh. I am submitting application and details as under.

1	Name & Address of the Applicant Firm			
	If Proprietorship			
	a) Name of Proprietor			
	b) Full Address			
	c) PAN number /GSTN No			
	If Partnership			
	a) Name of partners and their address			
	1.	2.	3.	
	b) Is partnership deed registered If yes then date of registration (attach copy of deed)			
	Yes / No	Date		
If Limited or Pvt. Limited Company under Indian Companies Act 1956.				
Limited or Private Limited				
Registered Office Address				
Date of Certificate of in Corporation				
2	Location of Production units			
3	Year of Establishment of the units.			
4.	Name, Designation & Mobile Number of Contact Person,			
5.	Name of Person Singing the TENDER (In Case Of Authorized Person Specific Power of Attorney has to be submitted)			
6.	Detail of turnover for last three year for the item quoted	YEAR	TOTAL TURNOVER (Rs. in Lacs)	TURNOVER IN MP (Rs. in Lacs)
		2018-19		
		2019-20		
		2020-21		

I here by confirm that all the above information is true to the best of my knowledge & belief. All the documents as required in the documents as enclose.

Date

Note: 1. Separate sheet may be used if necessary.
2. Strike out whatever not applicable.

Seal & Signature of the Bidder
or their authorized Representative



THE MADHYA PRADESH STATE AGRO INDUSTRIES DEVELOPMENT CORPORATION LIMITED

"PANCHANAN" 3rd FLOOR, MALAVIYA NAGAR, BHOPAL
Phone (0755)- 2551652, 2551756, 2761392, Fax: 0755-2557305

CONDITIONS OF RATE CONTRACT CONDITIONS OF RATE CONTRACT

1. PROCEDURE FOR RCO:

- 1.1 The Corporation invites online RCO for supply and installation of Material mentioned in **Annexure - III**.
- 1.2 Only one online RCO will be accepted from One Applicant / Firm. If any individual participating in the BID, representing more than one firm in one or different names and it comes to MP AGRO'S knowledge at any point of time, all such BID will not be entertained and shall be liable for rejection.
- 1.3 The bidders intending to participate in this RCO are required to get enrolled/registered on the www.mptender.gov.in. Enrolment / registration and subsequent empanelment on the above portal and sub portal is mandatory.
- 1.4 RCO documents can be purchased only online from <http://mptender.gov.in> by making online payment of portal fees etc.
- 1.5 It is the discretion of the Managing Director of the corporation to accept/reject the application without assigning any reason thereof.
- 1.6 BID in hard copies received after due date and time as stated above will not be accepted. When BID are delivered through messenger, the same should be deposited in the RCO box kept in the Marketing section of the Corporation on working days and during working hours.
- 1.7 The M.P. State Agro-Industries Development Corporation Ltd, will not be responsible delay in receipt of Bid on any account whatsoever. If BID is received after specific date and time, even if the delay is caused in postal transit, or any other reason whatsoever, the same shall not be considered and the BID will be rejected.
- 1.8 Telegraphic/Fax BID, or BID received over fax, e-mail etc. shall not be considered.

2. SUBMISSION OF RCO:

- 2.1 Corporation Invites online RCO for supply of material as mentioned in **(Annexure III)**. The Bidder will have to get themselves registered with www.mptender.gov.in for E-tendering, without registration BID cannot be uploaded on portal. To participate in Online RCO interested Bidder will be required Registration at Portal and valid class 3 digital signature certificates. An amount of Rs 4720/- as RCO fees to be deposited online through website www.mptender.gov.in that is to be paid by Bidder for registration under E-tendering.

- 2.2 All the Mandatory Documents (Self Certified with Seal and signature) shall be uploaded in JPG or PDF format only, in minimum resolution of 100 DPI. Document uploaded in other format will not be considered. **(Annexure - V)**
- 2.3 Self attested hard copies of all Mandatory Documents and RCO fees details (cost of documents) and EMD must be dropped in the envelope at Office of the Managing Director M P State Agro Industries Development Corporation Limited, IIIrd floor Panchanan Bhawan, Malviya Nagar, Bhopal, before last date and time of submission of BID.
- 2.4 The Envelope of Hard Copies shall be submitted in a sealed cover super prescribed with words naming RCO title mentioned at **(Annexure III)**

3. OPENING OF TECHNICAL BID:

Soft copies uploaded & Hard Copies received in the RCO box up to due date and time will be opened on due date and time as mentioned in **(Annexure III)** In case of any non clarity of uploaded documents or any dispute over documents uploaded online in e-RCO & submitted in hard copies given at **(Annexure V)**, hard copies submitted by the manufacturer shall be treated final.

4. DELAY IN SUBMISSION:

The Corporation will not be responsible for any delay on any account in receipt of RCO. If the BID is received after the specific date and time, even if the delay in receipt was caused in postal transit or any other reason, whatsoever.

5. CHANGE IN OPENING SCHEDULE:

RCO will be opened on due date and time as mentioned in **(Annexure - III)** point B in the presence of the representative of firms who wishes to be present. However if the date and time of opening of Technical Bid is changed due to any unforeseen reason the revised date and time of opening will be displayed on Portal/website of the corporation. No corrigendum will be issued through News Papers.

6. MODUS OPERANDI FOR THE PURCHASE & SALES OF THE ITEMS & QUOTING RATES BY BIDDER:

- (i) MP AGRO will buy material for onward sale to various Govt. Deptt. & farmers as per demand/requirement.
- (ii) Bidders are required to quote their selling rate to MP AGRO with the intention that MP AGRO will load its own margin (5% + GST) to the prices quoted by Bidders.
- (iii) Bidders are required to upload their rates online in the format prescribed for it.

- (iv) Rate list to be uploaded will be rates with GST & rate without GST. MP AGRO margin & GST thereon not to be included in this format.
- (v) Rates offered to MP AGRO should not be treated as rates to end user. Instead MP AGRO will work as dealer of the manufacturer. Manufacturer will be free to appoint their Sales Representative, other Dealer for after sales service & stocking purposes etc. Manufacturer can also incur expenses for sales promotion etc. as per their own policy.
- (vi) On the several occasions manufacturers do not quote lower rate to MP AGRO due to Price fall Clause executed by them with other organization. Difference between price quoted to MP AGRO & price quoted to other organization (for ultimate consumer) must be differentiated clearly that rate quoted to MP AGRO is the dealer rate.
- (vii) MP AGRO will be at full liberty to reduce or increase its margin at any time without consent from bidder. Managing Director Decision will be final & binding for all parties.
- (viii) The bidder should quote their lowest price, in accordance to the prevailing rates of the company to their other authorized dealer etc. Dealer rate may be decided by the company at its own on the basis of "**Dealer Rate**" prevailing for others dealer in Madhya Pradesh.
- (ix) M.P. Agro would like to execute agreements with all other eligible participants on the lowest rates, if they wish to do so.

7. Pre Bid Meeting :-

1. Pre Bid Meeting will be held on 22-07-2020 at 12:30 pm in the office of The MP State Agro Industries Development Corporation Ltd., 3rd Floor, Panchanan Bhawan, Malviya Nagar, Bhopal. Any change made in the time Schedule of Pre Bid Meeting shall be informed by uploading the Notice on Website.
2. Prospective bidder finds any difficulty, or discrepancy in the RCO documents, or want to submit any suggestion, the same can be submitted by bidder in writing in the Pre Bid Meeting on 06-07-2020.
3. Suggestions/information received in the Pre Bid Meeting will be examined by the corporation and, if any, correction needed in the RCO, same will be uploaded in the portal on 025-07-2020.
4. If no notice being uploaded on 25.07.2020, it will be presumed that 'no correction' in the existing document found necessary.

8. EXECUTION OF AGREEMENT :

- (a) The Corporation will intimate the successful Bidder regarding acceptance and request him to execute the agreement in given time limit. In case the Bidder fails to execute agreement within the prescribed time limit, the EMD submitted along with the RCO shall stand forfeited.
- (b) The successful Bidder shall have to execute an agreement as per **Annexure-XI** with the Corporation on non-judicial stamp paper of Rs. 1000/- (to be purchase by the Bidder)

9. EARNEST MONEY DEPOSIT:

- A. (i) RCO should accompany EMD as per clause C (**Annexure-III**)
(ii) Earnest Money of all unsuccessful Bidders will be returned.
(iii) No interest is payable on the amount of Earnest Money at the time of refund.
- B. Earnest Money shall be forfeited if :-
- (i) Deposit (EMD) is liable to be forfeited if the bidder withdraws or amends or impairs or derogates from the bid in any respect within the validity of the bid or is open for acceptance whether originally fixed or extended.
- (ii) No interest shall be payable by the Purchaser on the Earnest Money/**Bid** Guarantee to the Bidder.
- (iii) The Earnest Money shall remain deposited with the Purchaser during the validity period as mentioned, from the date of opening of RCO. If the validity of the offer is extended, EMD validity period deemed extended.
- (iv) Earnest money of successful Bidder will be adjusted as Security Deposit (SD) on execution of the agreement. (such Bidder will become supplier).

10. SECURITY DEPOSIT:

- (i) The SD will remain with the corporation during the currency of the contract and till successful execution of all the order placed during the currency of the contract and will be refunded to the supplier without interest in case of no dispute and after getting clearance/NOC from District Managers of the Corporation /purchasing officer.
- (ii) Security deposit will be forfeited in case of failure of supply of the material as mentioned in the purchase order, in time and as per the approved specifications, or for any breach of terms and condition of the agreement and RCO document.

11. MINIMUM TECHNICAL SPECIFICATIONS OF ITEMS

Minimum Technical specifications of the items covered in this RCO are the same as they are defined in (**Annexure - IV**) & **page no 29,30,31.**

12. PLACEMENT OF ORDER

Head Office / Regional Manager / Branch Manager of the Corporation shall place purchase order to the approved supplier.

13. SCHEDULE AND MODE OF SUPPLY / DELIVERY

- (a) The Bidder has to supply and deliver the ordered quantity within time period as mentioned in the order. Failure on the part of the Supplier for timely supply, shall lead to forfeiture of Security Deposit and the RCO shall stand cancelled and agreement shall be terminated. Corporation can also claim loss of goodwill as deemed fit and the same shall be payable by the Bidder.

- (b) If the indenting authority suffers any loss due to inordinate delay in effecting supply/ dispatch or arrival of the material at the destination, the same shall be the responsibility of the Bidder who shall make good the entire loss suffered by the indenting authority. The Managing Director will assess and intimate the Bidder the extent of loss, and the same will be acceptable to the Bidder. The supplier shall ensure that the ordered material being supplied by him reach the consignee at destination in good condition. As such it will be the sole responsibility of the supplier to ensure desired quality and standards of the material.
- (c) The ordered item as specified in order shall be in conformity with approved size and quality specifications mentioned in **Annexure-- IV & page no 29,30,31**, of the RCO and elsewhere in the RCO documents. Material shall be supplied in batches in any or all the sizes and in quantities as per delivery schedule ordered by the ordering authority of the Corporation. The delivery schedule may however be revised by the ordering authority, if warranted by exigency of the work of the Corporation. The successful Bidder shall be bound to effect deliveries in accordance with the changed supply schedule without claiming revision in rates. The dates of supply shall be the date on which the consignment reaches the required destination.
- (d) Ordered item may required to be supplied to the consignee through District Manager office of the corporation as per dispatch order given by the HO/RM/DM of the Corporation, securely packed so as to withstand rough handling and protection from vagaries of nature during transit.
- (e) Relevant L.R. shall be sent free and direct to the consignee (s) freight paid. The order No. of Corporation should be mentioned in the bill, against which the material is supplied.
- (f) The M.P. State Agro-Industries Development Corporation Limited shall not be responsible for damages, losses, thefts, pilferage, fire, accidents and demurrages etc. if any, incurred to the consignment during transit and these shall be borne by the supplier.
- (g) The dispatch of consignment shall be immediately communicated to the indenting HO/ Regional Manager/Disstt. Manager of Corporation and consignee with the relevant details of L.R. and Bill Nos.
- (h) **Transit Insurance:** The Supplier will arrange for Transit Insurance and Material supplied should be covered under Transit insurance for Road Risk, Theft, Pilferage, and Non Delivery Risk (**R RTPND**).

14. WARRANTEE:

The Bidder has to declare minimum One Years warrantee. Item supplied by the supplier having any manufacturing defect from the date of Installation. In case of complaint / defect the supplier shall have to arrange repair /replacement within 10 days from the date of receipt of intimation. The Corporation shall have right to recover the cost or expenditure of loss whatsoever, on this account from the future bills of the supplier or from the security deposit or from any other amount due to the supplier or out of the security or any deposit made by the supplier in other Government Organization.

15. TRAINING:

If required the supplier will impart training to the selected nominated person of purchaser and the concerned person/staff/officers of the Corporation for proper operation and maintenance of Items Supplied.

16. AFTER SALE SERVICE:

- a. The company must provide after sales service to the end user for warranty period.
- b. It shall be the responsibility of the supplier to ensure that necessary spares parts are available to the purchaser/customer of machine/equipments during warranty period and afterwards also. For this purpose Bidder shall keep necessary stock of such fast/slow moving parts on consignment with this corporation {MP Agro} or with their stockiest. Quantity and location of stocking points of such items shall be decided by the Bidder as per advice of Regional Managers/DM of this corporation.
Supplier shall also ensure that proper after sales services are available to the customers.
- c. The supplier shall also try to make arrangements for repair and after sale service required on continuous basis after expiry of the warranty period and shall ensure that the repairs/maintenance cost incurred by the purchaser are minimum.

17. RIGHT TO REFUSE/REJECT THE SUPPLIES:

- (a) Ordered item shall conform to the quantities specifications (as per **Annexure-IV & page no 29,30,31**) mentioned in supply order. The Corporation reserves the right to refuse to accept the supplied item, if found:-
 - (i) Inferior in quality & not in proper packing or not conforming to the specifications mentioned in **Annexure- IV & page no 29,30,31**.
 - (ii) Other than specified and ordered by the Corporation,
OR
 - (iii) For any other sufficient reason at it's discretion.
- (b) In case the supply of supplied item is rejected / the supply not accepted, shall be lifted by supplier at his own cost within the period granted by the M. P. State Agro-Industries Development Corporation Limited and in no case Corporation shall be liable for the supply not accepted.
- (c) If the material fails in the testing.

18. DEFECTIVE SUPPLIES:

The supplier shall replace the defective material or any other part found defective or prematurely worn out within 7 days within warranty period from the date of sale to the consumer, free of cost. If it is proved that Bidder has intentionally supplied machine/equipments of improper quality or not ready to replace or had not replaced defective machines / equipments during the specified period or in a genuine time period as required minimum, corporation shall be free to black list the Bidder and Bidder shall be bound to refund the amount received in lieu of such defective supplies made by the Bidder.

19. PAYMENT:

- (a) The Corporation will make the payment normally within 15 days on payment after payment condition to the supplier only after receipt of bills along with satisfactory report duly signed by the consignee/beneficiary.
- (b) In case these items are supplied to the farmer under various government schemes for providing subsidy, the farmer's share so received by the corporation shall be payable to the supplier along with work order after deducting corporation margin immediately.
- (c) As mentioned in the **(b)** above, remaining amount which will come by way of subsidy from the government shall be payable within 7 days on receipt of the same by the corporation.

20. PRICE ESCALATION CLAUSE:

The variation in price is allowed if any variation is occurred in GST slab & any levies/taxes by Regulatory authority. Bidder may Revised rates accordingly under intimation to corporation.

21. DISPLAY & DEPOSITION OF SAMPLES

One sample of items may be sought by the MP AGRO along with complete nomenclature & write-up. Corporation may decide to examine/check the samples for nomenclature & write-up submitted by supplier through recognized laboratories as decided by Managing Director of this Corporation.

22. RANDOM TESTING OF COMPONENTS:

Corporation may select sample by random sampling of any or all components of material received at the destination / site and send it to any recognized institute for testing. **The cost of such testing including cost of material shall be borne by the supplier.**

23. BRAND NAME:

The Bidder is entitled to claim only one brand name for the purpose of this contract. Regarding brand name, certificate of brand name, if any, issued by competent authority for this purpose should be made available, however the Corporation will not be liable for any dispute on account of brand name or of any kind related to Brand.

24. SUBMISSION OF REQUIRED DOCUMENT:

It is obligatory for the Bidder to submit all the necessary documents as mentioned in Annexure-V and mentioned elsewhere in RCO document. All formats should be filled in completely. **All the necessary documents should be enclosed duly self-attested.**

25. ACCEPTANCE/REJECTION OF RCO:

The Managing Director of the Corporation reserves the right to accept or reject any or all the RCO without assigning any reason whatsoever at any time prior to or after execution of agreement without incurring any liability to the affected Bidder and any obligation to inform the affected Bidder regarding the grounds.

26. FORCE MAJEURE CLAUSE:

FMC will be applicable in the following circumstances -

- (a) Natural phenomenon including but not limited to weather condition, floods, draught, earthquake and epidemics.
- (b) Acts of government authority domestic or foreign including but not limited to war declared or properties, quarantine restriction.
- (c) Accidents or distraction including but not limited to fire, explosion break downs at essential machinery equipment and power shortage.

27. PURCHASE PREFERENCE:

As per the policy of the State Govt. in respect of purchase of material for the use of corporation purchase preference to the extent of 30% shall be given to those manufacturer who belongs to the SC/ST category. A self certified photocopy of certificate issued by the concerned District Trade Industries Center to the effect that the Bidder's firm belongs to the SC/ST category in M.P. should invariably be attached. This clause will not be applicable if material is purchased by an individual or farmer.

28. TO IMPOSE PENALTIES:

The Managing Director of The Corporation reserves the right to impose penalties as per PMKSY Guidelines.

29. CORPORATION AS DEALER:

Corporation shall become Authorized Dealer of the company after execution of agreement with the company during the currency of Rate Contract.

30. ARBITRATION:

As far possible, all dispute arising out of this agreement will be settled by the mutual discussion and decision taken by the Dy. General Manager of the corporation will be final and binding on both the parties .

In case dispute is not settle as above then the same shall be referred to the arbitration. Arbitration and conciliation Act, 1996 shall apply to the proceedings before the Managing Director of the Corporation who shall be sole arbitrator. The decision of the arbitrator shall be final and binding on the parties.

31. RCO EVALUATION:

During RCO evaluation, MP AGRO may, at its discretion, ask the Bidder for a clarification of its RCO & documents attached thereto. The request for clarification and response shall be in writing or verbal.

32. RCO VALIDITY:

The rates finalized against this RCO shall be valid for a period of 1(one) year from the date of execution of agreement. It will be at the discretion of MP AGRO to extend/reduce validity period.

If mutually agreed corporation may extend validity period one year from the date of expiry of agreement so that validity period will not be more than two years.

33. MINOR MISTAKES IN RCO: MP AGRO may waive any minor nonconformity, or irregularity in a RCO document that does not constitute a material deviation, provided such waiver does not prejudice or affect the relative ranking of any bidder. Right to waive mistake shall remain with Managing Director of MP AGRO.

34. TRANSFERABILITY:

RCOs are not transferable.

35. RIGHT TO CHANGE CONDITIONS OF RCO:

- (i) MP AGRO reserves the right to reject or accept any RCO in whole or in part on account of credentials, technical capability, past performance or any other evaluation criteria to ensure uninterrupted supply of material. The decision of MP AGRO in this regard will be final and MP AGRO is not liable to assign any reasons for the decision.
- (ii) M.P. Agro reserves right to change any condition of this RCO during the currency of validity period.

36. PARALLEL RATE CONTRACT:

MP AGRO reserves the right (a) to enter into parallel rate contract(s) simultaneously or at any time during the period of the rate contract with more Bidders as MP AGRO may think fit, and (b) to place ad-hoc contract or contracts simultaneously at any time during the period of this contract with more supplier(s)/ Bidder(s) for such quantity and such item as the competent authority of MP AGRO (whose decision shall be final) may determine.

37. INSPECTION FOR QUALITY:

- (i) QCI approved third party inspection Agency i.e RITES/CIPET/EIL/IRS (IR class)/PDIL/SGS to certify materials or part thereof should be made available for inspection that materials are in accordance with the contract.
- (ii) All material supplied under this RCO will compulsorily inspected by Third Party approved by the Corporation for this purpose.
- (iii) Exps. Related to Third Party inspection shall be born by bidder.
- (iv) Inspection Report shall be submitted by bidder along with bills at the time of payment.

38. RISK PURCHASE CLAUSE:

MP AGRO reserves the right to make urgent purchase in case of failure of supply/ rejected supply either in part or full as per demand placed by the MP AGRO and any excess amount paid of such purchases should be adjusted from the registered supplier's Bill and may take following punitive actions.

- a) Fine to the tune of 2% of total amount supply not made/ degraded supply made may be imposed on the total value of the material for non supply/ short supply/ degraded supply etc. The fine amount will be deducted from the bill submitted for the next material supplied.
- b) The occurrence of such events 3 times during the contract period will lead to cancellation of contract by MP AGRO at any time after serving warning on each such event. The cancellation of contract will automatically come into effect from the last working hour of a scheduled delivery date after serving the last warning. On such event of cancellation the supplier will be black listed and will not be allowed to participate in any future RCO / supply contract for a period of one year. On event of cancellation of contract the security deposit available with MP AGRO for the contract will be forfeited.

39. WITH HOLDING AND LIEN IN RESPECT OF SUMS CLAIMED:

Whenever any claim or claims for payment of a sum of money arises out of or under the contract against the Contractor, MP AGRO shall be entitled to withhold and also have a lien to retain such sum or sums in whole or in part from security, if any, deposited by the supplier's and for the purpose aforesaid, MP AGRO shall be entitled to withhold the said cash security deposit or the security, if any, furnished as the case may be and also have a lien over the same pending finalization or adjudication of any such claims. In the event of the security being insufficient to cover the claimed amount or amounts or if no security has been taken from the Contractor, MP AGRO, shall be entitled to withhold and have lien to retain to the extent of the such claimed amount or amounts, from any sum or sums found payable or which at any time thereafter may become payable to the contractor under the same contract or any other contract with MP AGRO pending finalization or adjudication of any such claim.

40. CORRUPT PRACTICES:

Supplier is expected to observe the highest standard of ethics during the execution of this RCO. If the supplier has engaged in corrupt or fraudulent practices, in competing for or in executing the contract, MP AGRO may, after giving 14 days notice to the supplier, terminate the Contract. In pursuit of this policy, MP AGRO:-

a. Defines, for the purposes of this provision, the terms set forth below as follows:

- (i) "corrupt practice" means the offering, giving, receiving or soliciting of any thing of value to influence the action in the procurement process or in Contract execution; and

- (ii) “fraudulent practice” means a misrepresentation of facts in order to influence a procurement process or the execution of a contract to the detriment of MP AGRO and includes collusive practices among bidders (prior to or after bid submission) designed to get itself short listed for participating in the bidding process, to establish bid prices at artificial, non-competitive levels and to deprive MP AGRO of the benefits of free and open competition;
- b. Will reject a proposal for award if it determines that the Bidder being considered for award has engaged in corrupt or fraudulent practices in competing for the Contract.
- c. In the same manner as above, if bidder observes any corrupt practices or “fraudulent practice” in MP AGRO, he should report to Managing Director only.

41. BREACH OF CONTRACT:

Any breach of the terms & conditions mentioned in this RCO document by the Supplier, or any one employed by him or acting on his behalf (whether with or without the knowledge of the Supplier) or the committing of any offence by the Supplier or by any one employed by him or acting on his behalf under Chapter IX of the Indian Penal Code, 1860 or the Prevention of Corruption Act, 1988 or any other act enacted for the prevention of corruption by public servants shall entitle MP AGRO to cancel the contract and all or any other contracts with the Supplier and to recover from the Supplier the amount of any loss arising from such cancellation.

42. TERMINATION OF CONTRACT:

MP AGRO may initiate process for termination of Contract in the following event of default:

- (i) Breach of any of the terms or conditions or obligation of Contract on part of Supplier / his employees / agents.
- (ii) Any major material alteration in the agreed upon specification (if any) of the product to be supplied without the authorization of MP AGRO and / or competent authority.
- (iii) MP AGRO at their discretion may call for any record to satisfy themselves regarding supply of material to consignee units. The supplier shall provide every help/ document related to MP AGRO, failing which it may amount to breach of condition of the contract.
- (iv) The Supplier being adjudged bankrupt/ insolvent or a trustee/ receiver being appointed on the Supplier.
- (v) Repudiation of agreement by Supplier or otherwise evidence of intention not to be bound by the agreement.
- (vi) MP AGRO at their discretion may call for any record to satisfy them regarding the supply and Supplier will provide every help failing which it may amount to breach of condition of the Contract.

43. AMENDMENTS TO BID INVITATION:

The MP AGRO reserves the right, to make revisions or amendments to the bid documents, when deemed necessary, prior to the closing date of the bid, through proper notification or web-site. The bidders must watch MP AGRO web site for any such amendments. The MP AGRO shall be at liberty to consider extending the date set for the bid opening by such a number of days as in the opinion of the MP AGRO seems necessary.

44. NEGOTIATIONS:

- (i) It is clarified that normally the Corporation will make no negotiation on the RCO and therefore the Bidders should quote their lowest prices only. However the Managing Director of the Corporation may decide to give counter RCO of the lowest rate as decided by him.
- (ii) On the basis of lowest rate received in the financial bid corporation will ask other bidders to execute agreement provided other bidders are agreed to it.

45. AUTHORITY TO SIGN BID DOCUMENTS:

A person signing the RCO or any other document in respect of the Contract on behalf of the supplier without disclosing his authority to do so shall be deemed to warrant that he has authority to bind the Supplier. If it is discovered at any time that the person so signing has no authority to do so, MP AGRO may, without prejudice to any other right or remedy of MP AGRO, cancel the contract and make or authorize making of a purchase of the materials at the risk and cost of such person, and hold such person liable to MP AGRO for all costs and damages arising from the cancellation of the contract including any loss which MP AGRO may sustain on account of such purchase.

- 46.** Only Bhopal Court shall have jurisdiction.

**DY GENERAL MANAGER
(MARKETING)**

THE MADHYA PRADESH STATE AGRO INDUSTRIES DEVELOPMENT CORPORATION LIMITED

LETTER OF UNDERTAKING AND DECLARATION

We hereby submit RCO for the supply of PRECAST CONCRETE REINFORCED BENCH conforming to the Specifications as mentioned in RCO.

We undertake to supply such quantities of material as per Specification as mentioned in RCO, as we may be called upon to supply and install under the conditions here-to enclosed during the allotted period from the date of execution of the agreement on the rates agreed upon, at the places to be specified by the M.P. State Agro Industries Development Corporation Limited within the specified delivery period.

We undertake that our firm has neither been Blacklisted/Debarred by any Government / Government Undertaking /Bank nor penalized on the same ground. We also undertake that no legal proceeding is pending in any Courts on the same grounds.

We hereby agree to abide by and fulfill all the terms and conditions of contract annexed hereto and in default thereof to forfeit and pay to the M.P. State Agro Industries Development Corporation Limited, the penalties or sum of money mentioned in the said conditions.

The sum of Rs. 1,00,000.00 (One Lack only) in the form of Demand draft or any of the form specified in the Rate Contract RCO Documents is herewith forwarded as Earnest Money which shall be retained by The MP State Agro Industries Development Corporation Limited, on account of Security Deposit as specified in the clause 9 of the said conditions of contract, should this RCO be accepted.

"I have read and fully understood the terms and conditions of supplies etc. mentioned in the documents.

Name :.....

Designation:.....

(Signature with Office Seal..)

Witness:

1.

2.

THE RATE CONTRACT RCO IS HEREBY ACCEPTED BY ME ON BE HALF OF

M/s.....

SIGNATURE OF THE ACCEPTING AUTHORITY

Note: Letter of acceptance of RCO is to be submitted on non judicial stamp of Rs 500.00

**THE MADHYA PRADESH STATE AGRO INDUSTRIES DEVELOPMENT CORPORATION LIMITED**

"PANCHANAN" 3rd FLOOR, MALAVIYA NAGAR, BHOPAL
Phone (0755)- 2551652, 2551756, 2761392, Fax: 0755-2557305

FINANCIAL BID FORMAT

ITEM DESCRIPTION	UNIT	HSN CODE	BASIC RATE	GST Amount	GST %	PURCHASE PRICE TO MP AGRO
Precast concrete reinforced bench with armrest with seating capacity of four persons.	1 Nos.					
Precast concrete reinforced bench with armrest with seating capacity of three persons.	1 Nos.					
Precast concrete reinforced bench without armrest with seating capacity of two persons.	1 Nos.					

**Seal & signature
of the Bidder**

DECLARATION OF BLACKLISTING

I/We M/S hereby declare that neither I/We nor our Start-up or a parent, subsidiary or associate Company under direct or indirect common parent is/are presently nor in the past been placed on any Black list / Debar/Penalized by any Public Sector Company in India or by any Department of State or Central Government and that there is no pending inquiry by any Public Sector Company in India or by any Department of State or Central Government, against us or a parent, subsidiary or associate Company as aforesaid in India, in respect of criminal, corrupt or fraudulent practice(s), is NIL or details given hereunder.

It is understood that if this Declaration is found to be false, MP AGRO shall have the right to reject my/our proposal, and if the proposal has resulted in an investment, the investment agreement is liable to be terminated without prejudice to any other right or remedy (including Black list / Debar/Penalized) available to MP AGRO.

Place:

Date:

**Seal & Signature of the Bidder
or their authorized Representative**

NOTE: This declaration should be furnished on company's "Letter Head"

DRAFT AGREEMENT

***(THIS AGREEMENT TO BE FURNISHED AFTER THE BID IS
ACCEPTED ON NON JUDICIAL STAMP RS. 1000/-)***

This agreement made at Bhopal this day of , between The Madhya Pradesh State Agro-Industries Development Corporation, having registered office at Panchanan, 3rd Floor, Malviya Nagar, Bhopal, M.P. hereinafter referred to as 'Corporation' which expression shall unless repugnant to the context or meaning there of include its successors and assigns on the one part.

AND

M/s. ----- having its office at -----
----- acting through its (hereinafter referred to as the Supplier which expression unless repugnant to the context and meaning there of includes its assigns, successors and administrations on the other part.

WHEREAS the Corporation invited Rate Contract RCO for supply of PRECAST CONCRETE REINFORCED BENCH on the terms and conditions envisaged in the terms schedule issued with the Rate Contract RCO Document and purchased by the supplier.

AND WHEREAS the supplier has accepted each and every term and condition contained in the Rate Contract RCO Document, while submitting his RCO. The supplier has agreed to supply of quality materials and equipments on consignment basis on the terms and conditions of this agreement to the Corporation.

AND WHEREAS the Corporation accepted the RCO submitted by the supplier vide its letter of acceptance no. dated -----in consideration of the mutual premises and undertakings hereinafter specified and for other good and valuable consideration this agreement witness and is hereby agreed on the conditions of the RCO and the following documents shall form and be constructed a part of the Agreement Deed: -

-----2

- a) The terms & conditions of the Rate Contract Document
- b) Specifications of material
- c) The letter of acceptance dated -----
- d) The RCO submitted by the supplier.
- e) The rates mentioned in annexure to agreement.

The aforesaid documents shall be taken as complementary and mutually explanatory of one another but in case of discrepancies and ambiguities shall take precedence in the order set out above. In this regard the decision of Managing Director, M.P. State Agro-Industries Development Corporation Limited shall be final.

For Supplier

.....
.....
.....

For

M.P. STATE AGRO INDUSTRIES
DEVELOPMENT CORPORATION LTD

Signature with Office Seal

DY. GENERAL MANAGER MARKETING

Witnesses

- 1.
- 2.

SPECIFICATION FOR **PRECAST CONCRETE REINFORCED BENCH**

1. **DESCRIPTION** : This item shall govern the provision of supply, handling and installation of precast concrete reinforced benches with back rest and arm rest (if applicable).

There are three major designs of Precast concrete reinforced bench that consists of –

- i. Precast concrete reinforced bench with armrest with seating capacity of four persons.
 - ii. Precast concrete reinforced bench with armrest with seating capacity of three persons.
 - iii. Precast concrete reinforced bench without armrest with seating capacity of two persons.
2. **GENERAL REQUIREMENT** : The precast concrete reinforced benches shall be manufactured in accordance with the design requirements and details shown in the plan, and in conformity with the requirements of this specification.
3. **MATERIALS AND CONSTRUCTION METHODS** : The material and construction of precast concrete reinforced benches will be as follows:
 - i. **CONCRETE MIX DESIGN**: The benches shall be cast using M-30 Grade concrete mix in accordance with IS:10262: 2009 (with latest amendment) in grey cement by using vibro — compaction technique and with reinforcement as detailed in this specification. The manufacturer shall be responsible to design a mix which achieves both the strength and the surface finish required for the installation and application. Compressive strength shall be not less than **30 MPa at 28 days**.
 - ii. **REINFORCEMENT STEEL** : TMT reinforcement bars conforming to IS: 1786:2008 of dia 10 mm shall be used as main reinforcement bar and 4mm dia mild steel bars shall be used as stirrups as per reinforcement diagram.
 - iii. **CONNECTIONS** : 12mm dia x 65mm long galvanized steel CSK (Countersunk) bolts with EVA (Ethylene Vinyl Acetate) washer for connecting seating plank with leg and half threaded carriage bolts & nuts with EVA & steel washers of size 165mm length x 8 mm dia for connecting back rest plank with leg. Threaded steel fastener shall confirm to IS:1367 with latest amendments.
 - iv. **PAINT** : Red. Blue or orange colour acrylic-based paint (Another colour may be used, if decided by buyer) conforming to IS:15489 should be used.

4. **Details of member of precast concrete reinforced bench (for different variations, strictly refer to the drawings attached to this document)***
- i. **RCC BASE SUPPORTS** : Two number of legs manufactured using M-30 grade grey cement concrete. Each leg shall be reinforced with 4 nos. of 10mm dia TMT bars distributed uniformly along the section and periphery of the legs and tied with 4mm dia mild steel stirrups as per detailed given in drawing. Each leg will have 3 nos. 12mm dia 65mm length galvanized coupling nuts, welded suitably to the main reinforcement at appropriate locations on the seating to receive concrete planks on the legs.
 - ii. **PLANKS** : Two RCC planks shall be cast using M-30 Grade grey cement and each plank reinforced with 5 nos. 10mm dia TMT bars along the length and 10 nos. 4mm dia mild steel bars along the width and having 4 holes of 14mm dia at appropriate location to receive 12mm dia galvanized bolts for fixing these planks on the legs.
5. **FINISH** : Finish of concrete bench shall be generally equal to the approved sample. Exposed surface should exhibit a typically uniformly smooth texture with no bug holes and smooth mould seams.
6. **TOLERANCES** : All dimensions should be as per drawing ± 3 mm.
7. **PRODUCT DELIVERY, HANDLING AND STORAGE**
- i. Deliver materials to site, ready for use in the accepted manufacturer's original and unopened containers and packaging, bearing labels as type of material, brand name/manufacturer's name.
 - ii. Store materials under cover in a dry and clean location, off the ground. Remove delivered materials which are damaged or otherwise not suitable for installation from job site, and replace with acceptable materials.
8. **INSTALLATION OF RCC BENCH** : Each seating plank (bottom) of bench will be bolted with the leg with the help of 12 dia x 65mm length galvanized steel CSK (Countersunk) bolts with EVA (Ethylene Vinyl Acetate) washer. Back rest planks will be fitted with half threaded carriage bolts and nuts with EVA and steel washers of size 165mm length x 8mm dia.

After assembly of legs and planks at site, the hole visible at the back side of the bench will be sealed with cement mortar to prevent pilferage and plank will be painted with red colour acrylic-based paint (Other colours may be used, if decided by tendering authority). Head of bolts shall be grouted with epoxy resins like Araldite.

9. **MEASUREMENT** : The unit of measurement shall be as complete bench with two RCC Base supports and two planks and armrest (if applicable).
10. **PAYMENT** : The price shall cover the manufacturing, handling and installation on site (including labour, material, equipments and with FOR).

***There are different variations for different Precast concrete reinforced bench designs, strictly refer to the drawings attached to this document for accurate measurements.**

PRECAST CONCRETE REINFORCED BENCH WITH ARMREST WITH SEATING CAPACITY OF FOUR PERSONS.

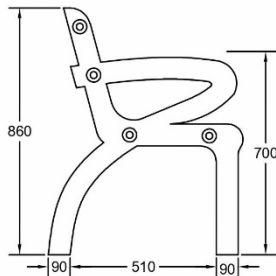

Side Elevation

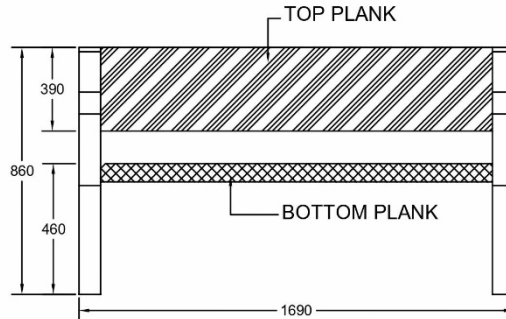

Front Elevation

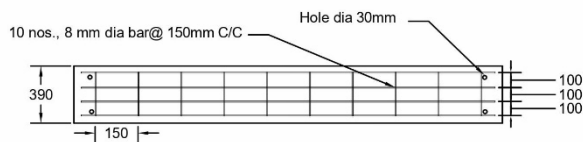

Reinforcement Plan of Top Plank
(1510mm x 390mm x 70mm)

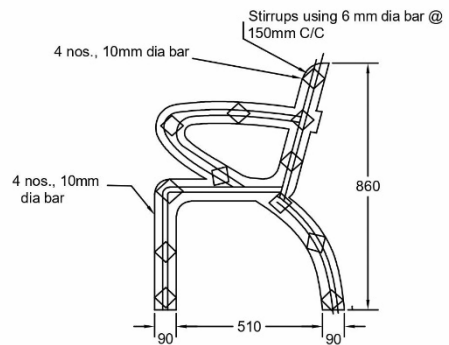

Reinforcement Detail of Leg

(Isometric View)

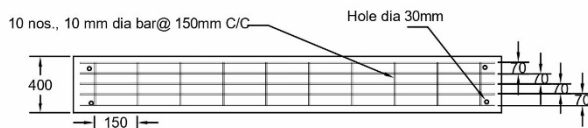

Reinforcement Plan of Bottom Plank
(1510mm x 400mm x 70mm)

- 1- Adequate clear Concrete Cover (Min. 15 mm) to be maintained everywhere.
- 2- Compressive strength of concrete mix shall not be less than 30 MPa at 28 days.
- 3- Surface finish shall be smooth and uniform.
- 4- All dimension are in millimeter.

PRECAST CONCRETE REINFORCED BENCH WITH ARMREST WITH SEATING CAPACITY OF THREE PERSONS.

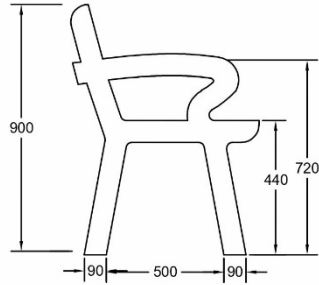

Side Elevation

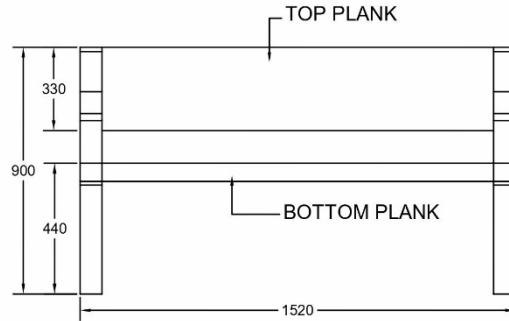

Front Elevation

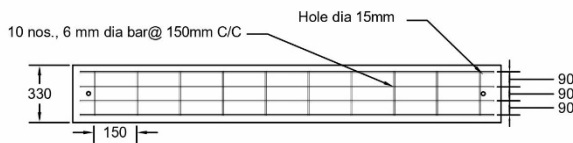

Reinforcement Plan of Top Plank
(1520mm x 330mm x 70mm)

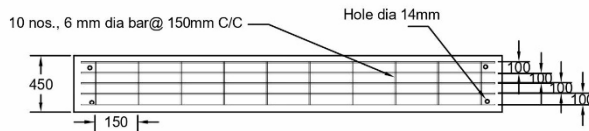

Reinforcement Plan of Bottom Plank
(1520mm x 450mm x 70mm)

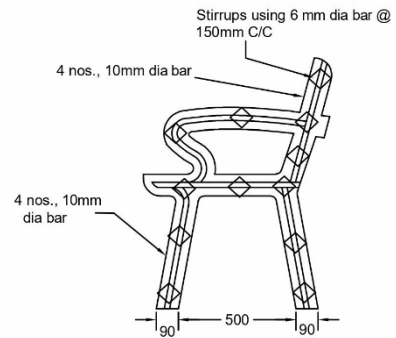

Reinforcement Detail of Leg

(Isometric View)

- 1- Adequate clear Concrete Cover (Min. 15 mm) to be maintained everywhere.
- 2- Compressive strength of concrete mix shall not be less than 30 MPa at 28 days.
- 3- Surface finish shall be smooth and uniform.
- 4- All dimension are in millimeter.

PRECAST CONCRETE REINFORCED BENCH WITHOUT ARMREST WITH SEATING CAPACITY OF TWO PERSONS

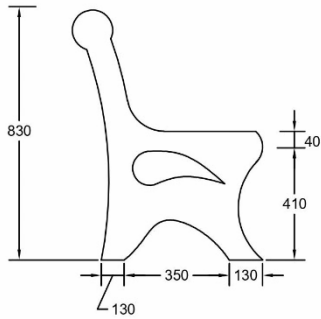

Side Elevation

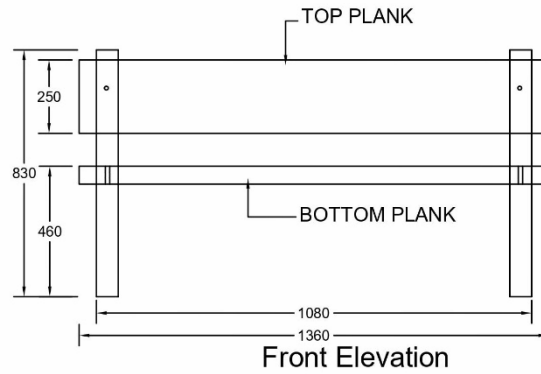

Front Elevation

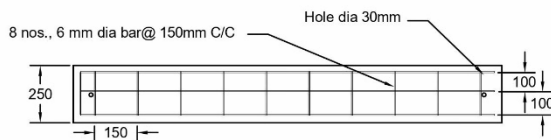

Reinforcement Plan of Top Plank
(1360mm x 250mm x 70mm)

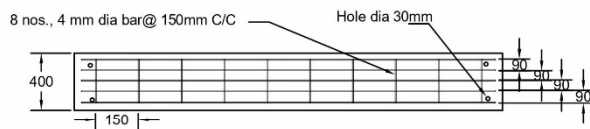

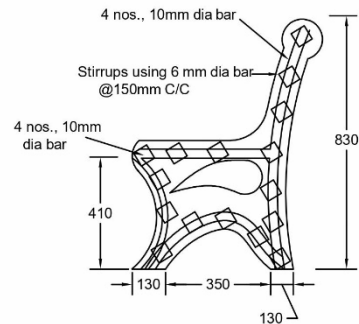

Reinforcement Plan of Bottom Plank
(1360mm x 400mm x 70mm)



Reinforcement Detail of Leg
(Isometric View)

- 1- Adequate clear Concrete Cover (Min. 15 mm) to be maintained everywhere.
- 2- Compressive strength of concrete mix shall not be less than 30 MPa at 28 days.
- 3- Surface finish shall be smooth and uniform.
- 4- All dimension are in millimeter.

SAMPLE - IMAGES

1	PRECAST CONCRETE REINFORCED BENCH WITH ARMREST WITH SEATING CAPACITY OF FOUR PERSONS
 <p data-bbox="735 701 1310 768">Curved Precast Concrete Reinforced Bench with Armrest</p>	
2	PRECAST CONCRETE REINFORCED BENCH WITH ARMREST WITH SEATING CAPACITY OF THREE PERSONS.
 <p data-bbox="560 1272 1078 1350">Precast Concrete Reinforced Bench with Armrest</p>	
3	PRECAST CONCRETE REINFORCED BENCH WITHOUT ARMREST WITH SEATING CAPACITY OF TWO PERSONS
 <p data-bbox="384 1899 1150 1977">Precast Concrete Reinforced Bench without Armrest</p>	